

BX Plus



Industrial Thermometer with Integrated RTD

INDUSTRIAL THERMOMETERS



- ▶ 9" Scale
- ▶ ± 1 Scale Division Accuracy
- ▶ Local Indication/Remote Data Acquisition
- ▶ 100Ω or 1000Ω RTD Sensors available



The Trerice **BX-Plus** has all the standard features of the original BX Series Industrial Thermometer, but with a "Plus". The "Plus" being an internally mounted 100Ω or 1000Ω RTD, allowing for remote temperature monitoring, while simultaneously providing local indication. This patented* dual sensor design eliminates the need for additional instrumentation or connections when designing a system to include both mechanical and electronic temperature sensing.

*U.S. Pat. Nos. 5,664,885 and 5,769,542.

- Optional features available: Please consult the Options & Accessories Section for details.
- These instruments are specifically designed for use with Trerice Digital Indicators (refer to the Electronic Temperature Sensor Section) and Electronic Controllers (refer to the Control Section).

MODEL BX3240307RTC

Specifications

Models	Scale Size	
BX9	9"	Adjustable Angle
BX1	9"	Rigid Straight
BX2	9"	Rigid 90° Angle
Fill Type	Spirit: Blue colored, organic	
Case	Cast Aluminum, blue epoxy finish	
Stem	Aluminum, Brass, or 304 Stainless Steel	
Process Connection	1 1/4-18 UNEF-2A coupling nut	
Electrical Connection	Molded cordset with coupling nut and six meter cable	
Window	Acrylic on ranges to 300° F Glass on ranges over 300° F	
Tube	Lens front, magnifying type	
Scale	Aluminum, white background with black graduations and markings	
Top Plate	Stainless Steel	
Sensor	International grade thin film platinum, 3-wire, 100Ω or 1000Ω RTD $\alpha = 0.00385\Omega/\Omega/^{\circ}\text{C}$	
Accuracy	Thermometer: ±1 scale division RTD: ±3°C or 0.6% of temperature	

Approximate Shipping Weight

- BX9: 1.9 lbs [0.86 kg]
- BX1: 1.7 lbs [0.77 kg]
- BX2: 1.6 lbs [0.73 kg]

HOW TO ORDER

Sample Order Number: **BX9 1 403 07 RTC**

Model	Stem Material	Stem (Length)	Specific Range	Sensor Type
BX9 9" Adjustable	1 Aluminum	403 3 1/2"	See	RTC 100Ω RTD
BX1 9" Straight	(standard)	406 6"	Standard	RTM 1000Ω RTD
BX2 9" 90° Angle	2 Brass	408 8"	Ranges	
	3 304 SS	512 12"		

Master Gauge Co.



WHEN UNDER PRESSURE THINK OF US!

1150 W. GRAND AVE. CHICAGO, IL 60642 - TOLL-FREE: 1-800-259-2705 - PHONE: 1-312-666-2705 - FAX: 1-312-666-6458 - MASTERGAUGECo.COM

All dimensions are nominal.
Dimensions in [] are in millimeters.

Adjustable-Angle

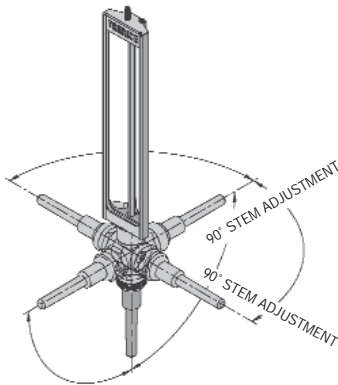
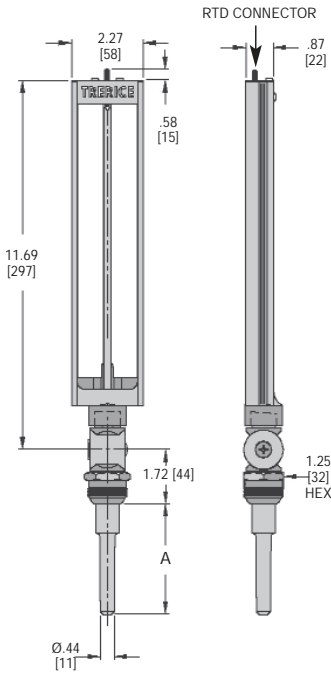

Rigid-Straight

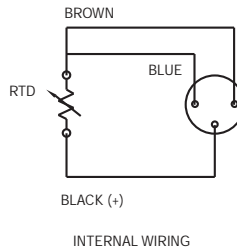
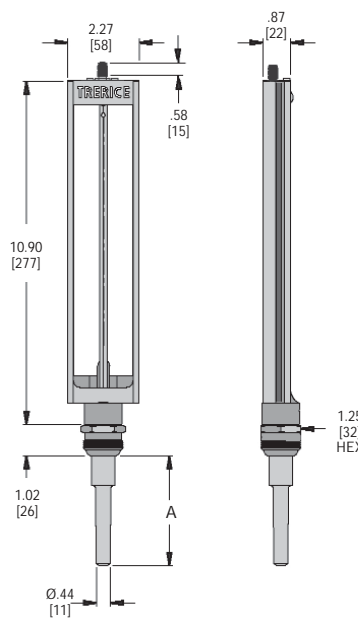

Rigid-90° Angle

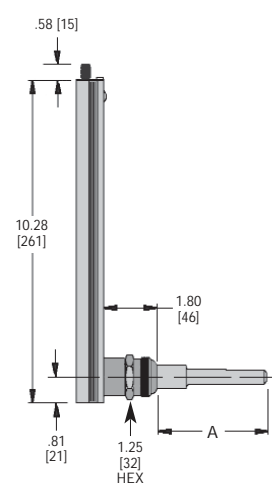

(A) Stem Length	Dimension
3 1/2"	3.50 [88.9]
6"	6.00 [152.4]
8"	8.00 [203.2]
12"	12.00 [304.8]

Standard Ranges

Fahrenheit Scale		Celsius Scale		Dual Scale		Fahrenheit		Celsius	
Range Code	Range	Range Code	Range	Range Code	Range	Figure Intervals	Minor Divisions	Figure Intervals	Minor Divisions
01	-40° to 110°F	17	-40° to 40°C	41	-40° to 110°F & -40° to 40°C	10°	2°	5°	1°
02	0° to 100°F	24	-18° to 38°C	42	0° to 100°F & -18° to 38°C	5°	1°	5°	0.5°
03	30° to 130°F	25	0° to 55°C	43	30° to 130°F & 0° to 55°C	5°	1°	5°	1°
04	0° to 160°F	26	-18° to 70°C	44	0° to 160°F & -18° to 70°C	10°	2°	5°	1°
06	30° to 180°F	27	0° to 83°C	46	30° to 180°F & 0° to 83°C	10°	2°	5°	1°
07	30° to 240°F	19	0° to 115°C	47	30° to 240°F & 0° to 115°C	10°	2°	5°	1°
08	30° to 300°F	20	0° to 150°C	48	30° to 300°F & 0° to 150°C	10°	2°	10°	2°
09	50° to 400°F	28	10° to 205°C	49	50° to 400°F & 10° to 205°C	25°	5°	10°	2°
15	50° to 500°F	31	10° to 260°C	55	50° to 500°F & 10° to 260°C	25°	5°	10°	2°

Dual scale figure intervals may differ

Master Gauge Co.



WHEN UNDER PRESSURE THINK OF US!

1150 W. GRAND AVE. CHICAGO, IL 60642 - TOLL-FREE: 1-800-259-2705 - PHONE: 1-312-666-2705 - FAX: 1-312-666-6458 - MASTERGAUGECo.COM