

# Bimetal Plus



Integrated Thermocouple or RTD

BIMETAL THERMOMETERS



MODEL B85606

- ▶ 3", 5" Dial Sizes
- ▶ ± 1.0% Full Scale Accuracy
- ▶ Local Indication/Remote Data Acquisition
- ▶ Thermocouple or RTD Sensors available

The Trerice **Bimetal Plus** has all the standard features of the Trerice Bimetal Thermometer, but with a "Plus." The "Plus" being an internally mounted thermocouple or RTD. This allows for remote temperature monitoring while still providing local indication. This dual sensor design eliminates the need for additional instrumentation or connections when designing a system to include both mechanical and electronic temperature sensing.

- Optional features available: Please consult the Options & Accessories Section for details.

**Thermowell**

- For corrosive or pressure applications, use of a thermowell is recommended to prevent damage to the thermometer and facilitate its removal from the process (refer to pages 155-161). For correct use and application of all Bimetallic thermometers, please refer to the Bimetallic Actuated Thermometer Standard ASME B40.3.

## Specifications

Models	Dial Sizes/Stem Styles
B836 B856	3" 5" } Adjustable Angle
B832 B852	3" 5" } Rear Connection
<b>Case</b>	300 stainless steel, hermetically sealed
<b>Stem</b>	300 stainless steel, 1/4" diameter
<b>Coil</b>	Bimetallic, silicone dampened on ranges to 300°F (148°C), above 300°F not dampened
<b>Process Connection</b>	Adjustable or rear, 1/2 NPT
<b>Electrical Connection</b>	T/C: Miniature plug RTD: Plug with molded cordset
<b>Window</b>	Double strength glass
<b>Pointer</b>	Balanced, black finished
<b>Dial Face</b>	Aluminum, white background with black and blue graduations and markings
<b>External Reset</b>	Yes
<b>Accuracy</b>	±1.0 % Full Scale ASME B40.3 Grade A
<b>Approximate Shipping Weight</b>	
	B832: 0.9 lbs [0.41 kg] B852: 1.4 lbs [0.64 kg] B836: 1.3 lbs [0.29 kg] B856: 1.7 lbs [0.77 kg]

### HOW TO ORDER

Sample Order Number: **B856 06 05 TCJ**

Model	Stem Length*	Range Code	Sensor Type
B836	04 4" Stem	See Standard Ranges	TCE Type E Thermocouple
B856	06 6" Stem		TCJ Type J Thermocouple
B832	09 9" Stem		TCK Type K Thermocouple
B852	12 12" Stem		TCT Type T Thermocouple
	15 15" Stem		RTC 100Ω RTD
	18 18" Stem		
	24 24" Stem		

Other lengths available: Specify in inches (48" maximum).  
\* Minimum insertion length is 3 1/2".

**Master Gauge Co.**



**WHEN UNDER PRESSURE THINK OF US!**

1150 W. GRAND AVE. CHICAGO, IL 60642 - TOLL-FREE: 1-800-259-2705 - PHONE: 1-312-666-2705 - FAX: 1-312-666-6458 - MASTERGAUGE.CO.COM

All dimensions are nominal. Dimensions in [ ] are in millimeters

### Adjustable Angle

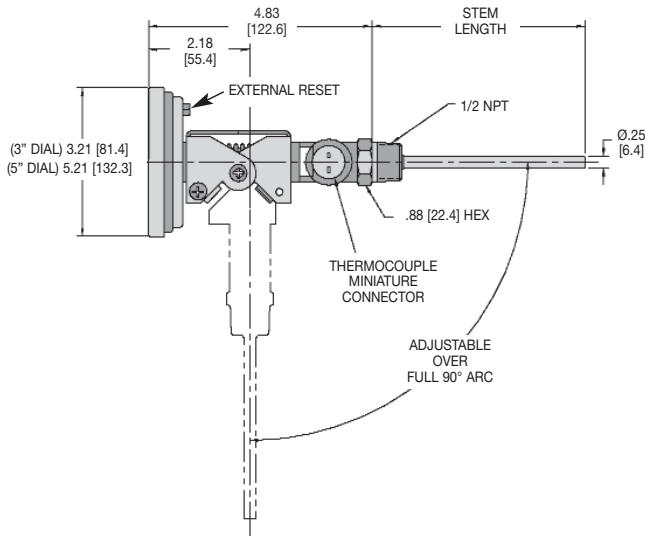

### Rear Connection

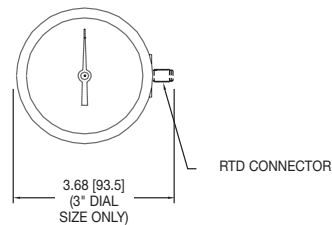
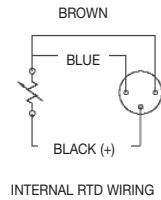
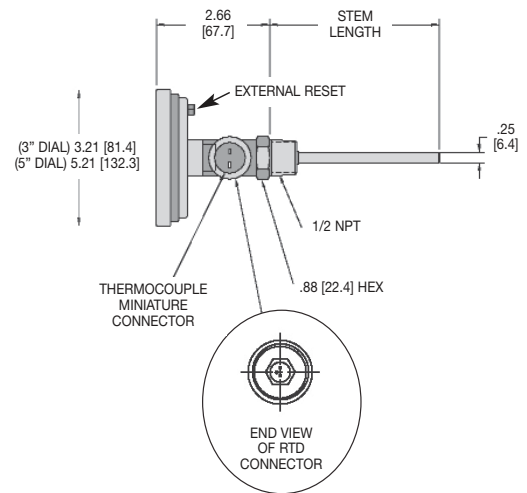

### Standard Ranges\*

Dual Scale (Fahrenheit & Celsius Range)		Fahrenheit Only Range		Celsius Scale Only Range		Fahrenheit		Celsius	
Range Code	Range	Range Code	Range	Range Code	Range	Figure Intervals	Minor Divisions	Figure Intervals	Minor Divisions
01	-100 to 100°F & -75° to 40°C	01F	-100° to 100°F	01C	75° to 40°C	20°	2°	10°	1°
02	-40° to 160°F & -40° to 70°C	02F	-40° to 160°F	02C	-40° to 70°C	20°	2°	10°	1°
12	0° to 100°F & -20° to 40°C	12F	0° to 100°F	12C	-20° to 40°C	10°	1°	10°	1°
03	25° to 125°F & -5° to 50°C	03F	25° to 125°F	03C	-5° to 50°C	10°	1°	5°	1/2°
04	0° to 200°F & -20° to 95°C	04F	0° to 200°F	04C	-20° to 95°C	20°	2°	10°	1°
05	20° to 240°F & -10° to 115°C	05F	20° to 240°F	05C	-10° to 115°C	20°	2°	10°	1°
27	0° to 250°F & -20° to 120°C	27F	0° to 250°F	27C	-20° to 120°C	50°	2°	20°	2°
06	50° to 300°F & 10° to 150°C	06F	50° to 300°F	06C	10° to 150°C	50°	2°	20°	2°
08	50° to 500°F & 10° to 260°C	08F	50° to 500°F	08C	10° to 260°C	50°	2°	50°	2°

\* Minimum insertion length for all ranges is 3 1/2".

# Master Gauge Co.



**WHEN UNDER PRESSURE THINK OF US!**

# Bimetal Plus

## Options & Accessories

BIMETAL THERMOMETERS

### Connection Head with Terminal Block or Transmitter

The connection head is designed to provide a weatherproof, yet accessible conduit connection, and is used to house a terminal connection block or Trerice TRT30 Temperature Transmitter. The head is available with a screw cover (cast aluminum or stainless steel) or a flip cover (polypropylene), and includes a 3/4 NPT conduit connection.

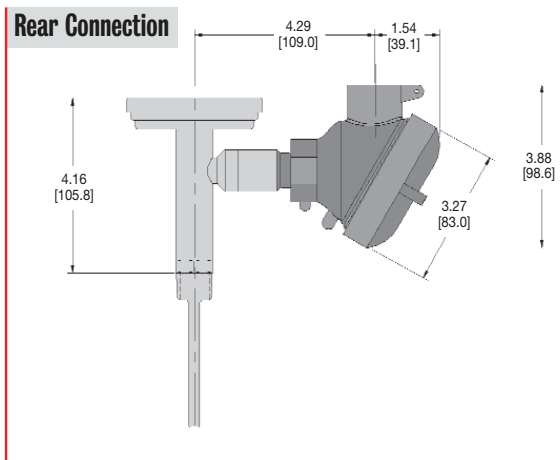
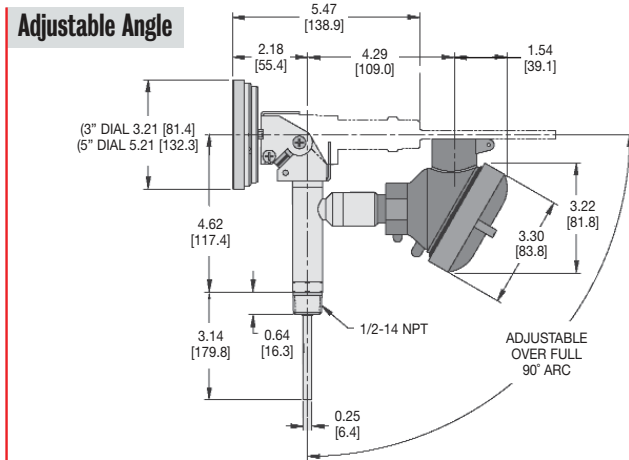

The terminal block provides an electrical hook-up point within the connection head, allowing for quick and easy attachment of extension wiring. The Terminal Block is available with either a 2-wire (thermocouple) or 3-wire (RTD) connection. The Trerice TRT30 Series Temperature Transmitter will convert a thermocouple or output signal to a 2-wire 4-20 mA signal, thus eliminating electrical interference and allowing the signal to be transmitted over long distances. These units are specifically designed for installation into the connection head.

**Transmitter**

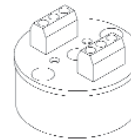

**Terminal Block**

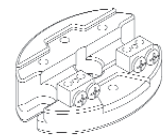

Specifications					
Model	Input	Accuracy	Adjustment Range	Maximum Output Load	Output Signal
TRT30	Type J, K or T Thermocouple or 100Ω Platinum RTD	±0.1% of input span	±35% for both zero and span	Thermocouple: R max=(V supply-12V)/20 mA RTD: R max=(V supply-10V)/20 mA	4-20 mA

### Ordering Codes

Connection Head	Terminal Block		Transmitter	
	Thermocouple	RTD	Thermocouple	RTD
Aluminum screw cover	ABT	ABR	ATT	ATR
Polypropylene flip cover	PBT	PBR	PTT	PTR
Stainless steel screw cover	SBT	SBR	STT	STR

### Weatherproofed Conduit Connection (WCC)

The conduit connection allows the Trerice Bimetal Plus Thermometer to be mounted directly to conduit piping, or used in applications where sprays and washes may come in contact with the electrical connection. This option consists of a stainless steel conduit connection tube, a packing grommet and a stainless steel connection fitting. Note: The Bimetal Plus with RTD Sensor does not require this option for weatherproof protection, as the RTD connection and cable are sealed for outdoor use. Please order using Option Code **WCC** (weatherproofed conduit connection).

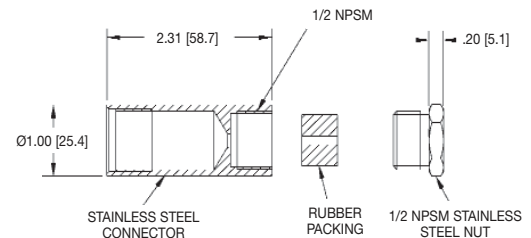

### How to Order

Specify the Optional Feature Code at the end of the Instrument Ordering Code. Sample Order Number: **B856 06 05 TJC WCC**

**Master Gauge Co.**



**WHEN UNDER PRESSURE THINK OF US!**