

INSPECTOR'S TEST GAUGE

- 3" Dial
- Vacuum to 1,000 psi Range
- Recalibrator on Dial Face
- ASME Grade 2A Accuracy

Marsh Inspector's Test Gauges are specifically designed for use by steam boiler, air brake and pressure system inspectors. The rugged 3" Inspector's Test Gauge features a nickel-plated case and an accuracy of $\pm 0.5\%$ of span. The bushed Mastergauge movement with Recalibrator is standard for these gauges. Mating parts are of dissimilar metals to prevent seizing. Bearing sleeves are of bronze, and the sector is brass.

Typical applications include steam boiler, air brakes, pressure system inspectors, and for use on other testing applications.

STANDARD RANGES & PART NUMBERS

TYPE	INSPECTOR'S TEST GAUGES
Size	3"
Case Material	Nickel Plated Brass
Internals	Copper Alloy
Mounting / Case Style	LM
Connection	1/4 NPT
Scale Standard	psi/kPa
0 to 30" Hg VAC	D1505
0 to 15 psi	D1540
0 to 30 psi	D1542
0 to 60 psi	D1546
0 to 100 psi	D1548
0 to 160 psi	D1552
0 to 200 psi	D1554
0 to 300 psi	D1558
0 to 600 psi	D1564
0 to 1,000 psi	D1572

ALL DIMENSIONS ARE NOMINAL

SPECIFICATIONS

ACCURACY
ASME Grade 2A - $\pm 0.5\%$ of span across full scale

CASE SIZES
3" diameter

CASE MATERIAL
Brass, Nickel Plated

CASE STYLE
Lower Mount with threaded ring

TUBE & SOCKET
Copper alloy

MOVEMENT
Brass

RECALIBRATOR
Standard

CONNECTION
1/4 NPT

RANGES
0 to 30" Hg VAC; 15 to 1,000 psi

DIAL STANDARD
Dual Scale psi/kPa

DIAL COLOR
Black markings on white

POINTER
Aluminum, black painted, knife-edge

WINDOW
Beveled glass

PROTECTIVE COVER
Opaque plastic lens cover

WEIGHT 2.0 lb.

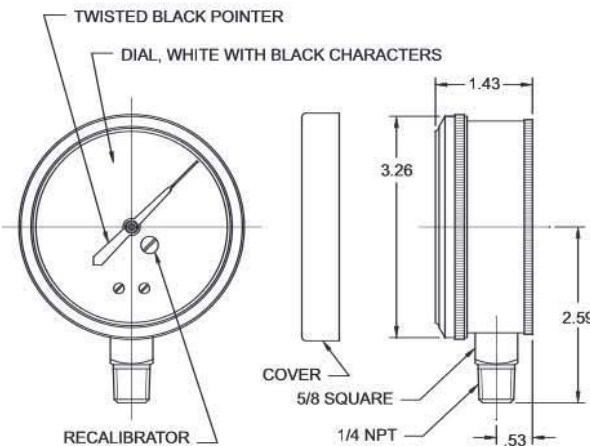

INSPECTOR'S TEST GAUGE OPTIONS

OPTION	TYPE	SUFFIX	AVAILABLE ON MODELS
Restrictors	Add restrictor	H	All ranges
Catalog Dials	psi only	E	See Marsh Price List for minimum
	bar only	L1	
	kg/cm ² only	L2	
	kPa only	L3	
	MPa only	L4	
	psi & bar	W1	
	psi & kg/cm ²	W2	
psi & MPa	W4		
Custom Dials	Logo or Custom Face	M	All models - consult factory

