

PRESSURE GAUGE SYPHON

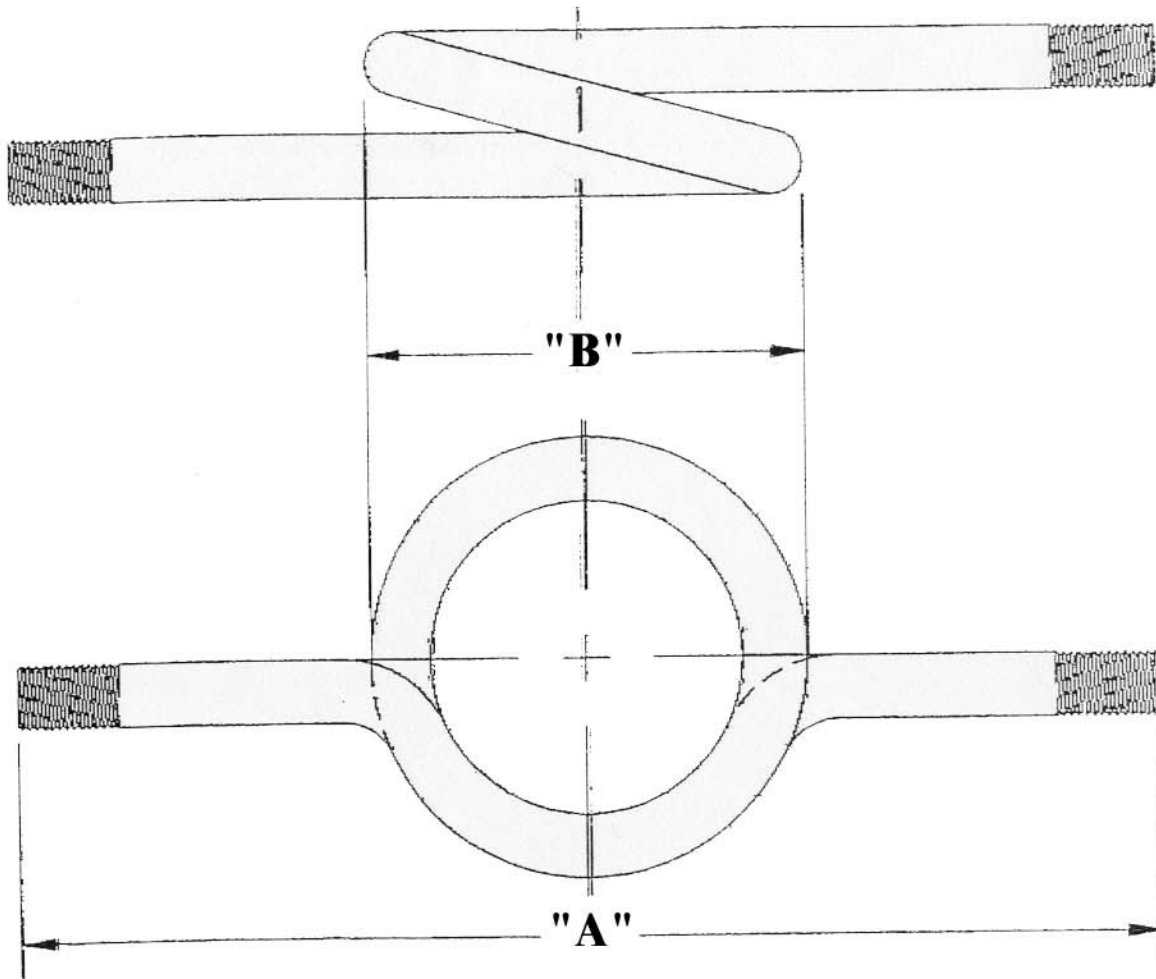

STYLE# 4

1/2"

A = 12" ± 1/4"

B = 4 1/8" ± 1/4"

1/4"

A = 7 1/4" ± 1/4"

B = 2 5/8" ± 1/4"

Master Gauge Co.



WHEN UNDER PRESSURE THINK OF US!

1150 W. GRAND AVE. CHICAGO, IL 60642 - TOLL-FREE: 1-800-259-2705 - PHONE: 1-312-666-2705 - FAX: 1-312-666-6458 - MASTERGAUGE.CO.COM

Maximum Working Pressure (PSI) 1/2" Pressure Gauge Syphons

Temp °F	Carbon Steel Sch80 (XH) SA- 53 CW	Carbon Steel Sch40 (STD) SA- 106B	Carbon Steel Sch80 (XH) SA- 106B	Carbon Steel Sch160 SA- 106B SMLS	Carbon Steel XXH SA- 106B SMLS	Chrome Moly Steel Sch80 (XH) SA-335	Chrome Moly Steel Sch160 SA-335 PA11	Chrome Moly Steel Sch80 (XH) SA-335	Chrome Moly Steel Sch 160 SA-335 P22	Chrome Moly Steel XXH SA-335 P22	Stainle ss Steel Sch40 (STD) SA-312 TP304	Stainle ss Steel Sch80 (XH) SA-312 TP304	Stainle ss Steel Sch160 SA-312 TP304	Stainle ss Steel Sch40 (STD) SA-312 TP316	Stainle ss Steel Sch80 (XH) SA-312 TP316	Stainle ss Steel Sch160 SA-312 TP316
20 to 100	1097	1117	2419	3926	8405	2419	3926	2419	3926	8405	1192	2580	4187	1192	2580	4187
200	1097	1117	2419	3926	8405	2419	3926	2419	3926	8405	1058	2290	3716	1117	2419	3926
300	1097	1117	2419	3926	8405	2419	3926	2419	3926	8405	953	2064	3350	991	2145	3481
400	1097	1117	2419	3926	8405	2419	3926	2419	3926	8405	871	1887	3062	909	1967	3193
500	1097	1117	2419	3926	8405	2419	3926	2419	3926	8405	819	1774	2879	842	1822	2957
600	1097	1117	2419	3926	8405	2419	3926	2419	3926	8405	767	1661	2696	797	1725	2800
650	1097	1117	2419	3926	8405	2419	3926	2419	3926	8405	760	1645	2669	782	1693	2748
700	1048	1072	2322	3769	8069	2419	3926	2419	3926	8405	745	1613	2617	767	1661	2696
750	935	968	2096	3402	7284	2387	3873	2419	3926	8405	730	1580	2565	752	1629	2643
800	-	804	1742	2826	6052	2322	3769	2419	3926	8405	708	1532	2486	737	1596	2591
850	-	581	1258	2041	4371	2258	3664	2322	3769	8069	700	1516	2460	737	1596	2591
900	-	372	806	1309	2802	2193	3559	2193	3559	7621	693	1500	2434	730	1580	2565
950	-	225	492	806	1781	1524	2499	1770	2902	6411	670	1451	2355	722	1564	2539
1000	-	114	254	426	1010	1068	1789	1356	2272	5388	655	1419	2303	715	1548	2512
1050	-	-	-	-	-	712	1193	966	1619	3839	640	1387	2251	708	1532	2486
1100	-	-	-	-	-	474	795	644	1079	2560	623	1360	2231	705	1541	2526
1150	-	-	-	-	-	322	540	407	682	1617	503	1118	1874	632	1406	2357
1200	-	-	-	-	-	203	341	237	398	943	396	881	1477	480	1068	1789
1250	-	-	-	-	-	-	-	-	-	-	305	678	1136	358	796	1335
1300	-	-	-	-	-	-	-	-	-	-	244	542	909	267	593	994
1350	-	-	-	-	-	-	-	-	-	-	190	424	710	198	441	738
1400	-	-	-	-	-	-	-	-	-	-	152	339	568	145	322	540
1450	-	-	-	-	-	-	-	-	-	-	122	271	454	114	254	426
1500	-	-	-	-	-	-	-	-	-	-	91	203	341	84	186	312

Notes:

- 1 These pressure temperature ratings are established on the basis of calculation in accordance with the ASME Boiler and Pressure Vessel Code, 1996 Edition, 1995 Addenda, Section 1, paragraph PG 27. It is the end user's responsibility to ensure that all components used in pressure retaining service are adequately designed for the anticipated conditions.
- 2 No allowance has been provided for corrosion.

Master Gauge Co.



WHEN UNDER PRESSURE THINK OF US!

Maximum Working Pressure (PSI) 1/4" Pressure Gauge Syphons

Temp °F	Carbon Steel Sch40 (STD) SA- 53 CW	Carbon Steel Sch80 (XH) SA-53 CW	Carbon Steel Sch40 (STD) SA106B SMLS	Carbon Steel Sch80 (XH) SA106B SMLS	Brass Regular SB-43 SMLS	Brass Extra Strong SB-43 SMLS	Chrome Moly Steel Sch40 (STD) SA-335 P11	Chrome Moly Steel Sch80 (XH) SA-335 P11	Stainless Steel Sch40 (STD) SA-312 TP304	Stainless Steel Sch80 (XH) SA-312 TP304	Stainless Steel Sch40 (STD) SA-312 TP316	Stainless Steel Sch80 (XH) SA-312 TP316
20 to 100	308	1046	679	2307	393	1635	679	2307	724	2461	724	2461
200	308	1046	679	2307	393	1635	679	2307	643	2184	679	2307
300	308	1046	679	2307	393	1635	679	2307	579	1969	602	2046
400	308	1046	679	2307	245	1022	679	2307	529	1800	552	1877
500	308	1046	679	2307	---	---	679	2307	498	1692	511	1738
600	308	1046	679	2307	---	---	679	2307	466	1584	484	1646
650	308	1046	679	2307	---	---	679	2307	462	1569	475	1615
700	294	1000	652	2215	---	---	679	2307	452	1538	466	1584
750	262	892	588	2000	---	---	670	2277	443	1507	457	1554
800	---	---	489	1661	---	---	652	2215	430	1461	448	1523
850	---	---	353	1200	---	---	633	2154	425	1446	448	1523
900	---	---	226	769	---	---	615	2092	421	1431	443	1507
950	---	---	136	469	---	---	423	1453	407	1384	439	1492
1000	---	---	69	242	---	---	289	1016	398	1354	434	1477
1050	---	---	---	---	---	---	193	677	389	1323	430	1461
1100	---	---	---	---	---	---	128	452	377	1297	427	1469
1150	---	---	---	---	---	---	87	306	303	1064	381	1339
1200	---	---	---	---	---	---	55	194	239	839	289	1016
1250	---	---	---	---	---	---	---	---	183	645	216	758
1300	---	---	---	---	---	---	---	---	147	516	161	564
1350	---	---	---	---	---	---	---	---	115	403	119	419
1400	---	---	---	---	---	---	---	---	92	323	87	306
1450	---	---	---	---	---	---	---	---	73	258	69	242
1500	---	---	---	---	---	---	---	---	55	194	50	177

Notes:

- 1 These pressure temperature ratings are established on the basis of calculation in accordance with the ASME Boiler and Pressure Vessel Code, 1996 Edition, 1995 Addenda, Section 1, paragraph PG 27. It is the end user's responsibility to ensure that all components used in pressure retaining service are adequately designed for the anticipated conditions.
- 2 No allowance has been provided for corrosion.

